

# Wren House Information

by John E. Wylie

**Construction:** Note that this house may be top-mounted, back-mounted or hung from a limb or porch. If it is to be back-mounted on a post or tree, the back should be 8 inches long-or you can nail a longer board to the back later to provide for back-mounting. As a substitute for eye screws, you can drill holes through the opposite edges of the roof boards and tie your wire there. Fasten the bottom in place with screws so that it can be removed to clean the box. The sides which fit under the roof can be beveled, but this is not necessary. A square cut works just as well. The 1 1/8-inch hole will keep out sparrows and larger birds.

**Installation:** Mount or hang the house six to ten feet high in or near a tree or shrub. House wrens seem to prefer areas with trees and shrubs. Fencerows and brushy draws are ideal. Bewick wrens seem to prefer more open countryside and frequent farmsteads more than urban lots. It pays to put up two or three wren houses in a back yard. The houses may be 20 to 50 feet apart. Males sometimes attract two females to use extra houses. They seldom build second or third nests in the same house in the same year; they move to one of the vacant houses instead.

**Comment:** Paper wasps or ants can sometimes be problems. Inspect and clean vacant houses.

**Biology:** Wrens arrive about April 10-20. Two and three broods per year are common. Normal clutch size is six to eight eggs. Incubation is about 15 days, and age to first flight another 15 days. They winter in the Southern states.

# HOW TO BUILD A WREN HOUSE



Drawings  
by Steve Gum

Missouri Department of Conservation

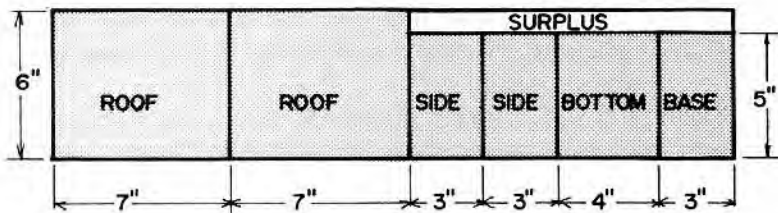

## LUMBER NEEDED

1/4" EXTERIOR PLYWOOD  
6" WIDE x 27" LONG  
(24" LONG IF BACK MOUNTED)

3/4" BOARD  
4" WIDE x 10" LONG  
(13" LONG IF BACK MOUNTED)

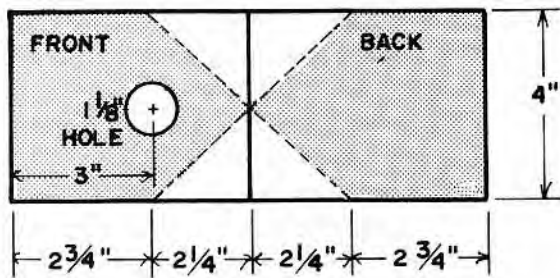

IF YOU WANT  
TO HANG  
USE EYE  
SCREWS  
AND WIRE

IF BACK MOUNTED TO POLE, ADD 3" TO BOTTOM  
OF BACK AND SHORTEN LENGTH OF ROOF 1"

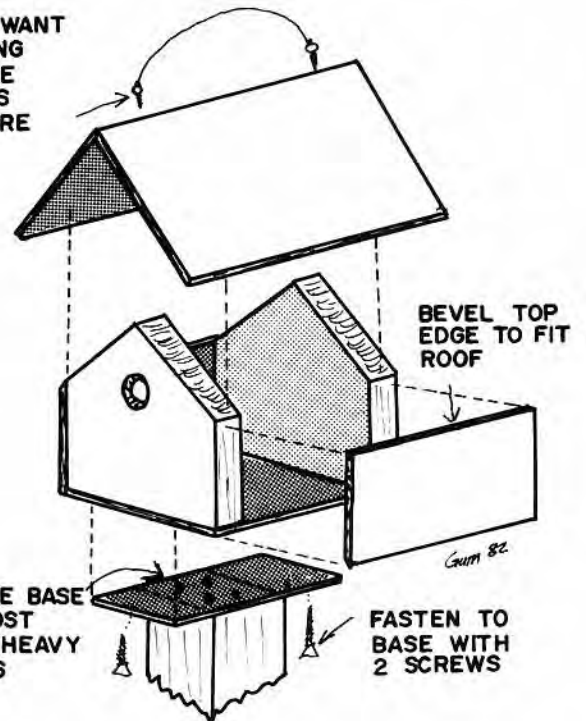
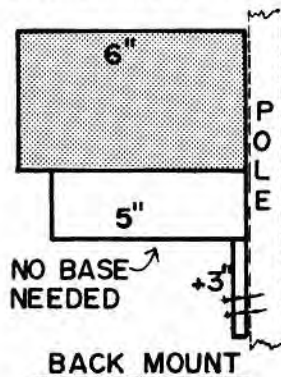
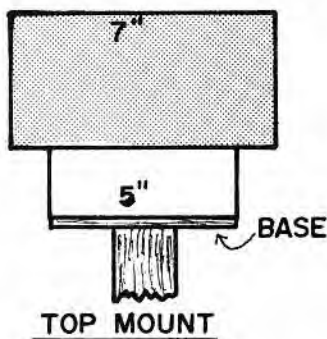

## TOP MOUNT ASSEMBLY